



RounBackIntake

Data Sheet

General Characteristics of Intake Roof Vent, RounBackIntake.

The round back intake roof vent is a hybrid design where the top 1/3 of the collar is closed.

This side needs to face the ridge of the roof.

As a result, this will prevent runoff from entering inside the vent.

The rest of the collar has 1/8 inch louvers that prevent rain, snow, insects, and animals from entering inside.

This 12 inch roof vent is ideal for roofs with a 2/12 roof pitch in climate zones 1-3.

This intake roof vent should be installed near the lower end of the roof.

To determine the number of vents you may need for proper attic ventilation, see the Vent Calculator.

The Round Back Intake Roof Vent will provide fresh air into the attic.

Without proper rooftop ventilation, heat and moisture may cause decay of the structure. In other words, ventilation helps to make a home more comfortable and Energy efficient.

Product Applications of Intake Roof Vent, RounBackIntake.

It adapts to residential and commercial buildings, as well as roofs with flat or steep slopes. A professional can install a Gravity Ventilator in any climate zone and on all types of roofs.

Refer to the Climate Zone Chart to determine the appropriate collar height for installation in your area. The installation of the Aura Gravity Ventilator is a simple process. Homeowners and professionals can install these vents on both new roofs and to replace old roof turbines.

Refer to the installation instructions provided by AVP to ensure proper installation and maximize the vent's effectiveness. Roof vents require no maintenance.

Warranty of Intake Roof Vent, RounBackIntake.

Manufacturer's Warranty: 1-Year



Active Ventilation Products





RounBackIntake

Data Sheet

Specific Characteristics of Intake Roof Vent, RounBackIntake.

Item #	Manufacturing #	Diameter	Tall Collar	NFA		IBC		Pitch Capacity		Weight and Dimensions with Packaging	
				Net Free Area		1/150	1/300	Min	Max (Modified)	Lbs.	W,H,D In
				Sq. in.	Sq. feet.						
USRBI-001	RBV-12-C2-IN	12"	2"	113	0.78	235	470	2/12	5/12	2	18,6,18

Dimensions (In.) of Intake Roof Vent, RounBackIntake.

Series	A	B	C	D	E	F
USRBI-001	17"	12"	1 3/4"	2 1/2"	16"	5"

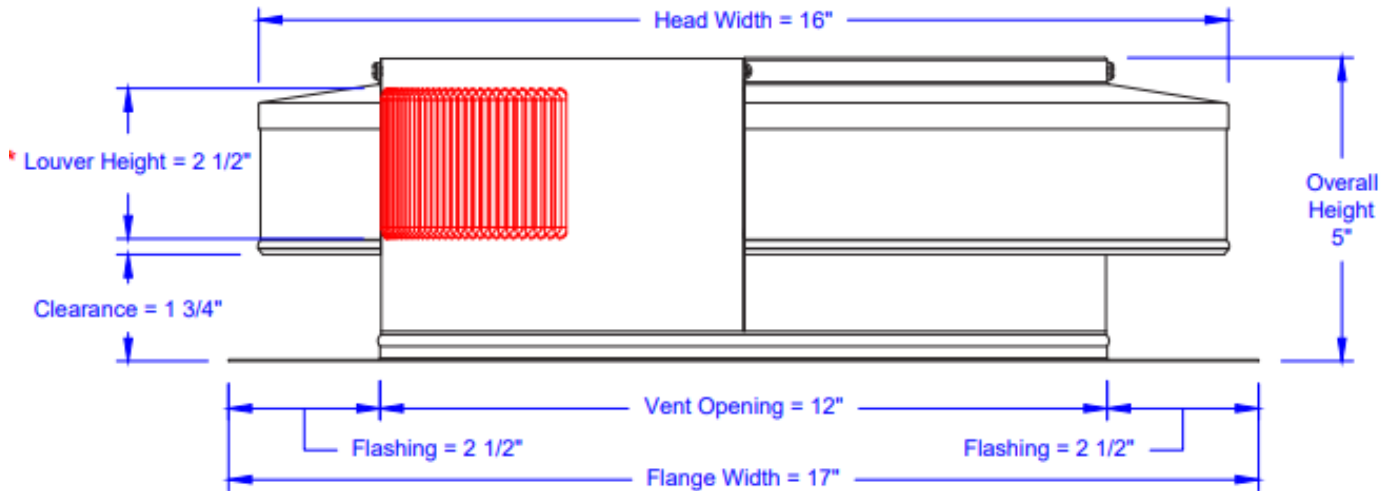



RounBackIntake

Data Sheet

Gallery Image of Intake Roof Vent, RounBackIntake.

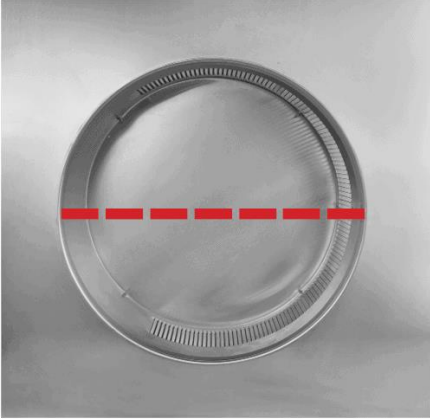

Diameter



2" Tall Collar



VentDepot.com

Ecological HVAC Supply & Engineering
1-888-514-1516, (626) 771-0048, F: (626) 771-0047
sales@ventdepot.com www.VentDepot.com

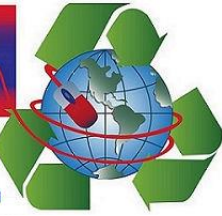

RounBackIntake

Data Sheet





RounBackIntake

Data Sheet

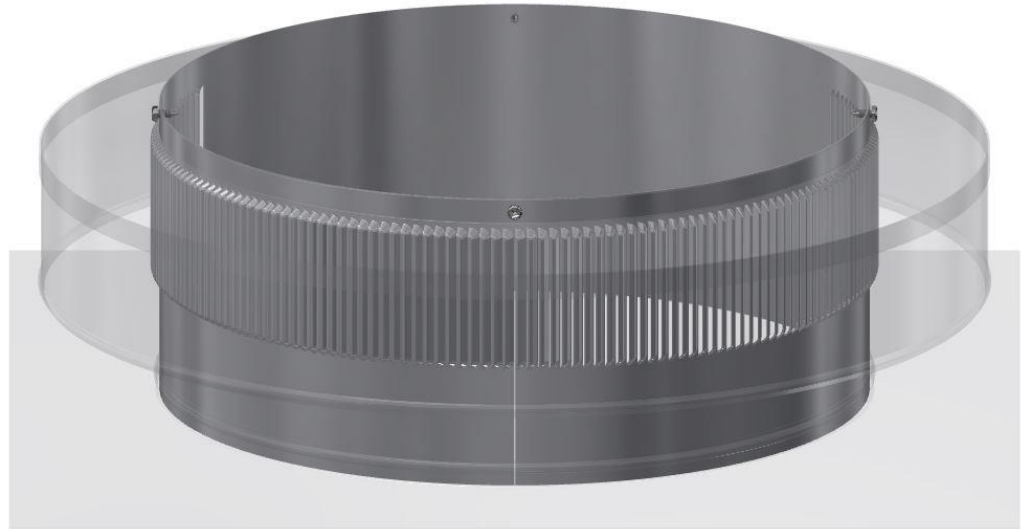

ID	Author	Description Error	Description Update	Supervisor Name
V1	Marcela Roldán	Technical Sheet Nueva	Technical Sheet Nueva	J.L.